

# A Hybrid Controller Design for VSC-HVDC Transmission System for PMSG Based Offshore Wind Farm

Ramu Srikakulapu, *Student Member, IEEE* and Vinatha U, *Senior Member, IEEE*

Department of Electrical & Electronics Engineering

National Institute of Technology Karnataka (NITK), Surathkal, India-575025

ramu.srikakulapu.in@ieee.org, u\_vinatha@yahoo.co.in

**Abstract**—Permanent magnet synchronous generator (PMSG) based offshore wind farm is connected to the onshore grid by voltage source converter (VSC) – HVDC link. The wind farm side VSC controls the AC voltage, and grid side VSC controls the reactive power and DC link voltage. This paper presents a non-linear control method for improving the robustness of the controller for VSC-HVDC link. A hybrid controller is designed using sliding mode control (SMC) and proportional-integral (PI) control. Mathematical modeling of the hybrid controller is presented. This hybrid controller has the capability of Fault Ride-Through and transient stability of VSC-HVDC link. This hybrid controller is simulated using the MATLAB/Simulink software and it is observed that the controller provides better performance. Transient stability is ensured by creating a symmetrical fault at the grid side in the simulation.

**Index Terms**—AC voltage control, DC voltage control, high voltage direct-current, offshore wind farm, reactive power control, sliding mode control, voltage source converter.

## PARAMETERS

$\lambda$	Sliding co-efficient.
$\lambda_{AC}$	Sliding co-efficient of AC voltage controller.
$\lambda_{DC}$	Sliding co-efficient of DC voltage controller.
$\phi$	Boundary layer thickness .
$\phi_{AC}$	Boundary layer thickness for AC voltage controller.
$\phi_{DC}$	Boundary layer thickness for DC voltage controller.
$d_m$	Duty cycle.
$e_m$	Phase voltage.
$i_{DC}$	DC current.
$i_m$	Phase current.
$r$	Switch resistance.
$r_f$	Filter resistance.
$C_f$	Filter capacitor.
$K$	Switching gain constant.
$K_{AC}$	Switching gain of AC voltage controller.
$K_{DC}$	Switching gain of DC voltage controller.
$K_{I-AC}$	Integral gain of AC voltage controller.
$K_{I-CC}$	Integral gain of inner current controller.
$K_{I-DC}$	Integral gain of DC voltage controller.
$K_{P-AC}$	Proportional gain of AC voltage controller.
$K_{P-CC}$	Proportional gain of inner current controller.

$K_{P-DC}$	Proportional gain of DC voltage controller.
$L$	Phase reactor inductance.
$L_{tf}$	Transformer inductance.
$P$	Active power.
$Q$	Reactive power.
$R$	Phase reactor resistance.
$V_{DC}$	DC-link voltage.
$V_g$	Grid voltage.
$V_{PCC}$	Voltage at the PCC.

## I. INTRODUCTION

In recent times wind energy is taking a major proportion of renewable energy. The share of wind energy installation is increasing at a faster rate in global energy scenario. Of the wind energy installations, offshore wind farms (OSWFs) have gained more importance compared to onshore wind farms due to the abundant availability of wind velocity and provision of installing high rated wind turbines. The high rated OSWFs are located on a sea and from shore to hundreds of km distance. These offshore wind farms are connected to the grid using high voltage direct current (HVDC) link. HVDC transmission system is a best economical way for distances greater than 50-60 km from shore [1] and it transmits the huge amount of generated wind power from OSWF to onshore AC grid. The HVDC transmission system is classified into current source converter (CSC) - HVDC and voltage source converter (VSC) - HVDC. Thyristor and IGBT switching devices based converters are used in CSC and VSC HVDC systems respectively [2]. The VSC based HVDC has various advantages compared to CSC based HVDC. Those are (a) VSC gives independent control of reactive and active power without using additional compensating devices, (b) It can be connected to weak and isolated areas, (c) it has black start capability, (d) it can be easily installed at offshore site because of flexible and compact size, (e) no communication required between the both side VSCs, and (f) it requires lower AC harmonic filtering because of it has higher switching frequency devices.

Some of the researchers have worked on the controllers based on proportional – integral (PI) for VSC-HVDC transmission link. The distributed voltage and frequency controls are proposed for OSWF and it is connected with diode based HVDC link in [1]. In [3] authors have proposed hybrid twelve-

pulse diode rectifier with VSC at wind farm side which controls the DC voltage of HVDC link. A multi-task control strategy is applied for VSC-HVDC in [4]. It deals with power management between the VSCs, AC voltage control at sending-end side VSC, and DC voltage control at receiving-end side VSC. In [5] authors have used dynamic aggregated model of OSWF for analysis the dynamic stability of OSWF connected to the grid through VSC-HVDC. Frequency regulation scheme is proposed in [6] and it allows VSC-HVDC link to contribute the frequency regulation of system by varying the DC-link voltage. A novel hybrid VSC-HVDC link is proposed in [7]. It is the combination of twelve-pulse diode rectifier with VSC and twelve-pulse SCR converter with VSC is applied at sending-end converter and receiving-end converter respectively. In [8] authors have employed multi-variable PI controller for inner-loop control and single-input-single-output PI controller for outer-loop control to design the controller for VSC-HVDC link. A novel power coordination method is proposed in [9] to maintain the DC voltage stability and it consists of dynamic braking resistor at grid side VSC and two droop controllers.

The conventional control methods have limitation to tune the parameters of the nonlinear system and it degrades the performance of the system [10]. The motivated points for the design of controller based on sliding mode control (SMC) are parametric uncertainties, nonlinearities, and bandwidth limits. Since OSWFs are highly nonlinear systems, controller design much be robust, nonlinear and adaptive type, so that it improves the transient stability of power system [11]. So, advanced control technique based controllers give a better outcome for grid integration of OSWFs. In literature, authors have worked on the controllers based on advanced control techniques for various issues of VSC-HVDC system. Authors [12] have used adaptive sliding mode control to design controllers for rectifier and inverter of VSC-HVDC link. A robust nonlinear control method based on SMC is adopted to design the controllers for VSC-HVDC link and it is enhanced the system performance and stability [10]. The genetic algorithm based SMC [13], inertia emulation based SMC [14], and perturbation observer based SMC [15] are proposed for design hybrid VSCs on both sides of VSC-HVDC link. It improves the system dynamic stability and controls the power oscillations. The fuzzy logic controller based three-level neutral point clamped VSC is applied to transmit the power in VSC-HVDC link [16]. In [17] adaptive back stepping method is used to integrate the OSWF to the grid and it is focused to stabilize the DC voltage. A sensor-less control strategy based on extended Kalman filter is proposed to develop the controller of VSC-HVDC and it controls the DC link voltage [18].

In this paper, permanent magnet synchronous generator (PMSG) based OSWF is connected to onshore AC grid by VSC-HVDC transmission link. The objectives of VSC-HVDC link controller are constant DC-link voltage, AC voltage control, and reactive power control. To fulfill these objectives appropriate controller is required at both terminals of VSC-HVDC link. The hybrid control strategy is used to design the

controller and it consists of inner and outer controllers. The inner controller and outer controller are designed based on PI control and robust nonlinear control method respectively. The robust nonlinear approach is based on sliding mode control as it stabilizes the VSC-HVDC system.

Section II explains the system modeling and it includes mathematical modeling of VSC, AC filter, and grid. The nonlinear control technique based on SMC is discussed in section III. Section IV explains the design of a hybrid controller for VSC-HVDC link. The simulation and analysis of proposed control strategy and conclusion are enlightened in consequent sections.

## II. SYSTEM MODELING

The single line diagram of PMSG based OSWF with VSC-HVDC transmission link is shown in Fig.1. The OSWF is having 400 MW power generation capacity and the PMSG wind turbines are connected in a radial manner. The single line diagram consists of OSWF, VSC based HVDC link, and grid. The wind farm side VSC (WSVSC) is connected to grid side VSC (GSVSC) through the DC cable. The specifications and parameters of the system are described in Table.1. The circuit diagram of three phase VSC, AC filter, and grid are shown in Fig .2 [2].

The mathematical model of VSC is given in (1-3).

$$C \frac{dV_{DC}}{dt} = \sum_{m=1}^3 i_m d_m - i_{DC} \quad (1)$$

$$L \frac{di_m}{dt} + Ri_m = e_m - V_{DC} d_m - \frac{1}{3} \sum_{m=1}^3 d_m \quad (2)$$

$$\sum_{m=1}^3 e_m = \sum_{m=1}^3 i_m = 0 \quad (3)$$

The Clarke and Park transformation is applied to get dq model equations of VSC are given in (4-6).

$$C \frac{dV_{DC}}{dt} = \frac{3}{2} (i_q d_q + i_d d_d) \quad (4)$$

$$L \frac{di_q}{dt} - \omega L i_d + R i_d = e_q - V_{DC} d_q \quad (5)$$

$$L \frac{di_d}{dt} - \omega L i_q + R i_q = e_d - V_{DC} d_d \quad (6)$$

The three phase AC filter mathematical model is given in (7,8).

$$C_f \frac{de_m}{dt} = i_{c_m} \quad (7)$$

$$i_{c_m} = i_{PCC_m} - i_m \quad (8)$$

The dq model equations of AC filter is given in (9-12).

$$C_f \frac{de_d}{dt} = \omega C_f e_q + i_{c_d} \quad (9)$$

$$C_f \frac{de_q}{dt} = -\omega C_f e_d + i_{c_q} \quad (10)$$

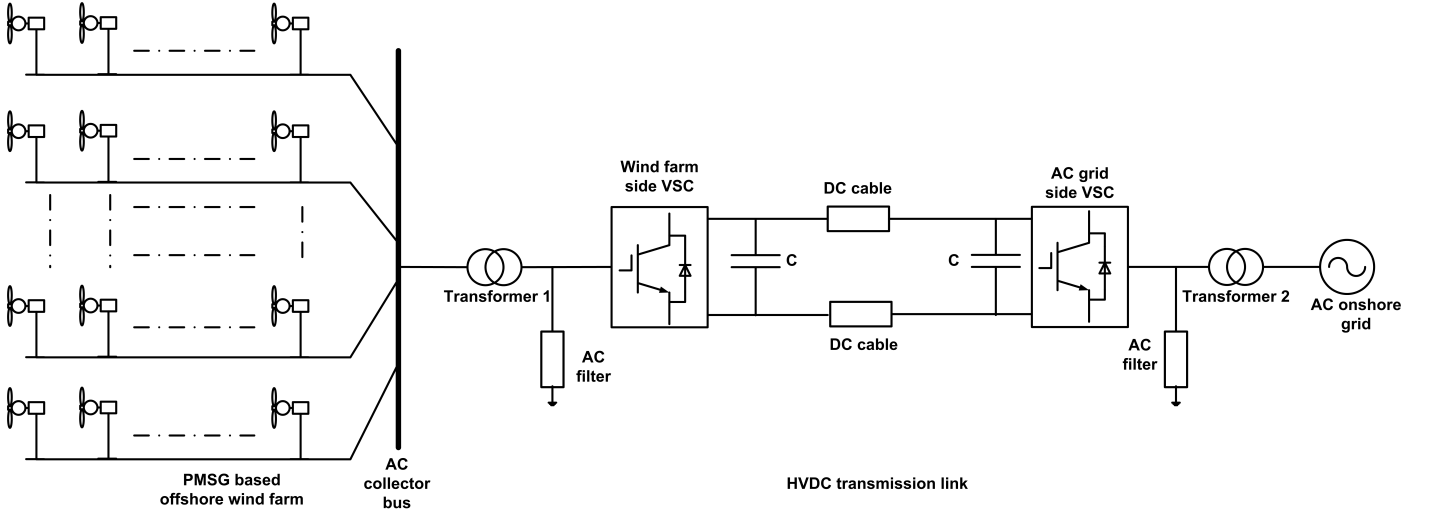

Fig. 1. The single line diagram of PMSG based OSWF with VSC-HVDC transmission link

$$i_{c_d} = i_{PCC_d} - i_d \quad (11)$$

$$i_{c_q} = i_{PCC_q} - i_q \quad (12)$$

The grid model can be designed by using the Thevenin's equivalent circuit and the voltage equation of grid model is given in (13).

$$V_g = R_g I_g + L_g \frac{di_g}{dt} + V_{PCC} \quad (13)$$

tune the parameters of the nonlinear system and it degrades the performance of the system [10]. SMC is efficient method to design a robust controller for complex higher order nonlinear systems under different ambiguity conditions. The low sensitivity to variations of parameters and disturbances are the benefits of SMC. The chattering phenomenon is the major drawback of SMC when it is using in high-frequency applications. To overcome the chattering problem by continuous functions such as saturation, Signum, and hyperbolic tangent functions are used [10]. The mathematic equations of SMC is as follows: The sliding surface  $S$  is given in (14).

$$S = \lambda e + \dot{e} \quad (14)$$

where  $\lambda$  is sliding coefficient and  $e$  is the error signal of  $x$ .

$$e = x_{ref} - x \quad (15)$$

The discontinuous control action  $\tau_c$  is shown in (16)

$$\tau_c = K \tanh \frac{S}{\phi} \quad (16)$$

$$V = \frac{1}{2} S^2 \quad (17)$$

where  $V$  is the positive definite Lyapunov function and  $\dot{V}$  must be negative definite  $V < 0$  to ensure the system stability.

$$\dot{V} = S\dot{S} \quad (18)$$

#### IV. CONTROLLER DESIGN FOR VSC-HVDC LINK

The hybrid control strategy includes the inner controller and outer controller. The outer and inner controllers are designed by using the SMC technique and PI control respectively. The function of the inner controller is to control the current such that it follows the reference supplied by the outer controllers.

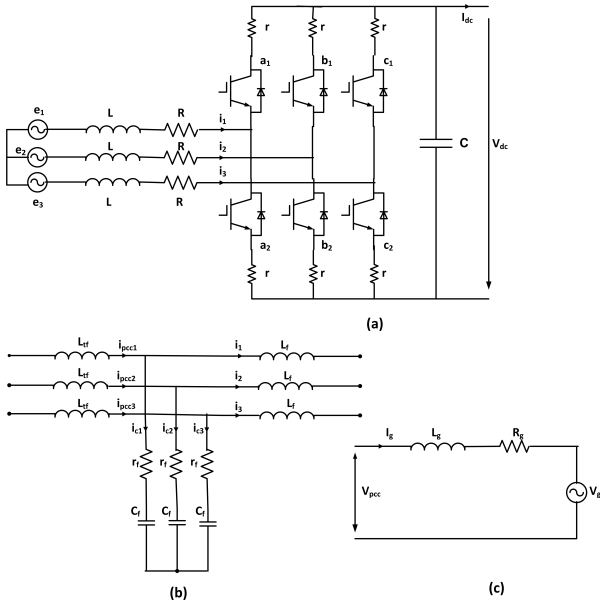

Fig. 2. Circuit diagram of (a) three phase VSC, (b) AC filter, and (c) grid

#### III. SLIDING MODE CONTROL

SMC is a non-linear control method and it is developed by V.Utkin in the 1950s. The PI control method has limitation to

The inner current controller gives the dq voltage output to PWM generator through the dq to abc converter and it ensures the VSC is not overloaded in fault or disturbance conditions. The WSVSC consists of AC voltage and current controllers act as outer and inner controllers respectively. The AC voltage control is appreciated by controlling the voltage droop over the AC filter's capacitor and it is designed by using (9)-(12) and (14)-(17). The AC voltage controller provides the reference currents  $i_d$  and  $i_q$  to the inner current controller. The GSVSC consists of DC voltage controller and reactive power controllers act as an outer controller. The DC voltage controller regulates the DC link voltage. The stable DC link voltage ensures the stable power flow between the VSCs. The reference of reactive currents is achieved by using the instantaneous power equations as given in (19) and (20).

$$P = e_d i_d + e_q i_q \quad (19)$$

$$Q = e_q i_d - e_d i_q \quad (20)$$

$$i_q^* = \frac{P^* e_q + Q^* e_d}{e_d^2 + e_q^2} \quad (21)$$

The reactive power controller is obtained by using (21). It controls the reactive power to a minimum level. Hence, it minimizes the transmission current and reduces the transmission losses. The hybrid controller designs of WSVSC and GSVSC are shown in Fig. 3.

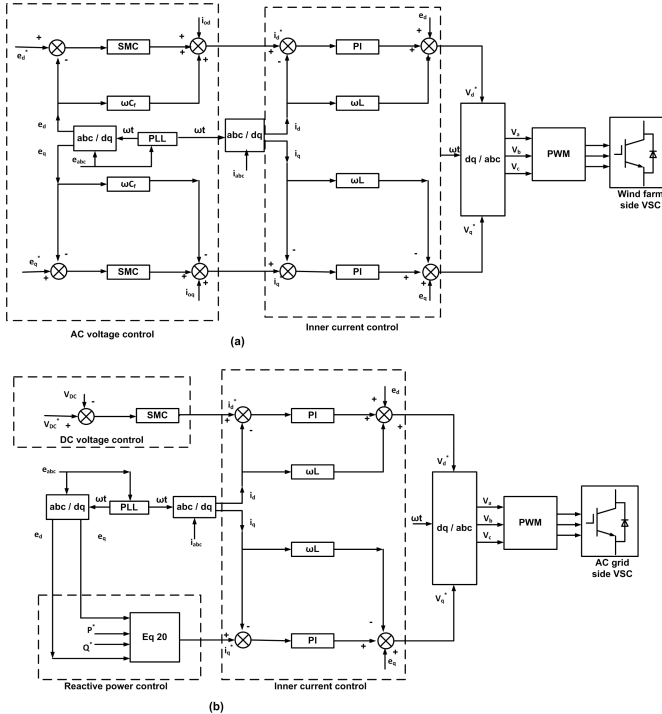

Fig. 3. Hybrid controller designs of (a) WSVSC and (b) GSVSC

## V. SIMULATION RESULTS AND ANALYSIS

The simulation studies of PMSG based OSWF with VSC-HVDC transmission link is executed in MATLAB/Simulink software for proposed hybrid control strategy. The parameters of specified power system and tuned gain values of controllers are described in Table 1. The responses of proposed strategy and conventional method based controllers are investigated by the Fault Ride-Through capability and transient system stability of VSC-HVDC link. Therefore, it can be decided which control strategy is better suitable for VSC-HVDC system. To validate the power system Fault Ride-Through capability, LLLG fault is applied near to the grid terminal between the time intervals of 2.1 to 2.22 seconds. The wave forms of the source voltage and grid voltage for both controller strategies are shown in Fig. 4. The fault condition response can be observed in grid voltage waveform.

TABLE I  
SPECIFICATIONS OF POWER SYSTEM

Sub system	Parameters	Values
Wind farm side system	Rated power of WT	1.5 MW
	Rated power of OSWF	400 MW
	Transformer 1	33/150 kV <sub>ph-ph,rms</sub>
DC link	Length	75 km
	Capacitor (C)	290 μ F
Grid side system	Transformer 2	150/400 kV <sub>ph-ph,rms</sub>
	Grid voltage	400 kV <sub>ph-ph,rms</sub>
AC filter	Inductance	1 μ H
	Capacitance	79.578 μ F
	Resistance	11.21 ohms
WSVSC gain values	$K_{P-AC}$	3.2258
	$K_{I-AC}$	29353
	$K_{P-CC}$	0.0312
	$K_{I-CC}$	208.17
	$K_{AC}$	4
	$\lambda_{AC}$	6.1864
	$\phi_{AC}$	5
GSVSC gain values	$K_{P-DC}$	2.8402
	$K_{I-DC}$	25820
	$K_{DC}$	4
	$\lambda_{DC}$	5.4419
	$\phi_{DC}$	5

The responses of DC link voltage and reactive power of grid for both controller strategies are shown in Fig. 5. The observations of Fig.5. are (a) DC voltage of PI base controller is stabilized at 3 sec with 0.67 pu, (b) DC voltage of hybrid controller is stabilized at 2.5 sec with 1 pu, and (c) grid reactive power is stabilized at negative side and zero for PI based controller and hybrid controller respectively. The settling time of the DC link voltage based on a hybrid controller is less compared to PI controller. However, the hybrid controller is providing robust controllability in faulty conditions. In the case of a hybrid controller based VSC, the grid reactive power

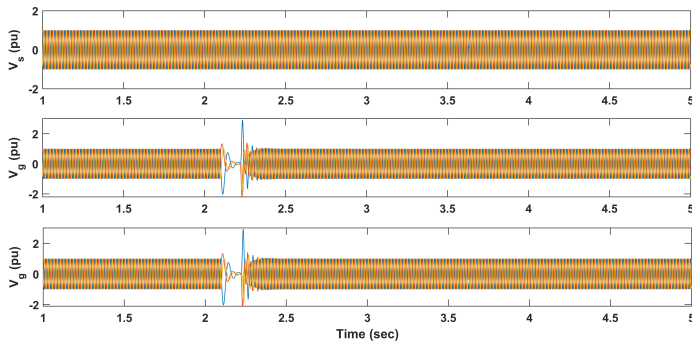

Fig. 4. (a) Source voltage, (b) grid voltage for PI controller, and (c) grid voltage for hybrid controller based system

is stable at zero and it leads to the power system operates at unity power factor.

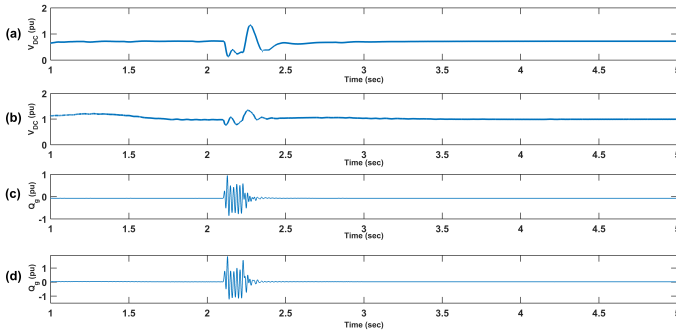

Fig. 5. DC link voltage for (a) PI controller, and (b) hybrid controller based system and grid reactive power for (c) PI controller, and (d) hybrid controller based system

## VI. CONCLUSION

This paper presented a hybrid control strategy to design a robust controller for VSC-HVDC and it is connected the on-shore AC grid and 400 MW OSWF. A hybrid control strategy is a combination of sliding mode control and conventional PI control. The mathematical modeling of VSC-HVDC link and SMC are explained. The proposed controller is designed for WSVSC and GSVSC to regulate the AC voltage, reactive power, and DC link voltage of power system. The proposed controller has given best responses for AC voltage control, grid reactive power control, and DC voltage control. It stabilizes the DC link voltage and reactive power of grid. However, it leads to maintain stable power transfer between the VSCs. The robustness of hybrid controller is investigated under the LLLG fault by examining the Fault Ride-Through capability.

## REFERENCES

[1] R. Blasco-Gimenez, S. Ano-Villalba, J. Rodríguez-D'Érlée, F. Morant, and S. Bernal-Perez, "Distributed voltage and frequency control of offshore wind farms connected with a diode-based hvdc link," *IEEE Transactions on Power Electronics*, vol. 25, no. 12, pp. 3095–3105, 2010.

[2] A. IS and D. IS, "Control of vsc-hvdc transmission system for offshore wind power plants," *Master of Science Thesis, Aalborg university*, 2010.

[3] T. H. Nguyen and D.-C. Lee, "Control of offshore wind farms based on hvdc," in *Energy Conversion Congress and Exposition (ECCE), 2012 IEEE*. IEEE, 2012, pp. 3113–3118.

[4] O. Giddani, A. Y. Abbas, G. P. Adam, O. Anaya-Lara, and K. Lo, "Multi-task control for vsc-hvdc power and frequency control," *International Journal of Electrical Power & Energy Systems*, vol. 53, pp. 684–690, 2013.

[5] D. Kong and X.-P. Zhang, "Modelling and control of offshore wind farm with vsc-hvdc transmission system," 2010.

[6] H. Liu and Z. Chen, "Contribution of vsc-hvdc to frequency regulation of power systems with offshore wind generation," *IEEE Transactions on Energy Conversion*, vol. 30, no. 3, pp. 918–926, 2015.

[7] T. H. Nguyen, Q. A. Le, and D.-C. Lee, "A novel hvdc-link based on hybrid voltage-source converters," in *Energy Conversion Congress and Exposition (ECCE), 2015 IEEE*. IEEE, 2015, pp. 3338–3343.

[8] J. K. Pradhan, A. Ghosh, and C. Bhende, "Small-signal modeling and multivariable pi control design of vsc-hvdc transmission link," *Electric Power Systems Research*, vol. 144, pp. 115–126, 2017.

[9] A. Egea-Álvarez, M. Aragués-Peñalba, E. Prieto-Araujo, and O. Gomis-Bellmunt, "Power reduction coordinated scheme for wind power plants connected with vsc-hvdc," *Renewable Energy*, vol. 107, pp. 1–13, 2017.

[10] H. S. Ramadan, H. Siguerdidjane, M. Petit, and R. Kaczmarek, "Performance enhancement and robustness assessment of vsc-hvdc transmission systems controllers under uncertainties," *International Journal of Electrical Power & Energy Systems*, vol. 35, no. 1, pp. 34–46, 2012.

[11] A. Colbia-Vega, J. de Leon-Morales, L. Fridman, O. Salas-Pena, and M. Mata-Jimenez, "Robust excitation control design using sliding-mode technique for multimachine power systems," *Electric Power Systems Research*, vol. 78, no. 9, pp. 1627–1634, 2008.

[12] R. Mallick, "Adaptive sliding mode control of vsc-hvdc transmission links," in *Energy, Automation, and Signal (ICEAS), 2011 International Conference on*. IEEE, 2011, pp. 1–6.

[13] M. Ahmed, M. Ebrahim, H. Ramadan, and M. Becherif, "Optimal genetic-sliding mode control of vsc-hvdc transmission systems," *Energy Procedia*, vol. 74, pp. 1048–1060, 2015.

[14] K. Mahapatra and P. Dash, "Inertia emulation based sliding mode control of vsc hvdc system for transmission of power from onshore wind farms to ac grids," in *Power, Communication and Information Technology Conference (PCITC), 2015 IEEE*. IEEE, 2015, pp. 522–528.

[15] B. Yang, Y. Sang, K. Shi, W. Yao, L. Jiang, and T. Yu, "Design and real-time implementation of perturbation observer based sliding-mode control for vsc-hvdc systems," *Control Engineering Practice*, vol. 56, pp. 13–26, 2016.

[16] S. Muyeen, R. Takahashi, and J. Tamura, "Operation and control of hvdc-connected offshore wind farm," *IEEE Transactions on Sustainable Energy*, vol. 1, no. 1, pp. 30–37, 2010.

[17] X. Zhao and K. Li, "Control of vsc-hvdc for wind farm integration based on adaptive backstepping method," in *Intelligent Energy Systems (IWIES), 2013 IEEE International Workshop on*. IEEE, 2013, pp. 64–69.

[18] M. Benadja and A. Chandra, "Adaptive sensorless control of pmsgs-based offshore wind farm and vsc-hvdc stations," *IEEE Journal of Emerging and Selected Topics in Power Electronics*, vol. 3, no. 4, pp. 918–931, 2015.