

Effect of unbalance in voltage supply on the detection of mixed air gap eccentricity in an induction motor by Motor Current Signature Analysis

R.L.Samaga, K.P.Vittal
Dept of E&E, NITK-Surathkal
India

Vikas J
Dept of E&E, MIT-Manipal
India

Abstract— Condition monitoring units are employed in industries to monitor the health of the machines continuously. Air gap eccentricity fault is one of the asymmetrical faults which can result in the machine failure. Motor Current Signature Analysis and Vibration Analysis are the two most popular methods used for eccentricity fault detection in the induction motor. In this paper, a study conducted on an induction motor to analyse the effect of supply voltage unbalance on the method of eccentricity fault detection by Motor Current Signature Analysis is presented. A dynamic model of the induction motor suffering from air gap eccentricity and has the capability to take unbalance supply voltage is developed and the results obtained by simulating this model are validated by the experiments conducted on an induction motor suffering from inclined mixed eccentricity and fed with unbalance voltage supply.

Keywords- air gap eccentricity, data acquisition system, induction motor, Motor Current Signature Analysis.

I. INTRODUCTION

Induction Motors are widely used in industries as they are more reliable. But they too suffer from asymmetrical faults such as stator turn-turn fault, rotor fault, bearing fault and air gap eccentricity fault [1,2]. Industries employ fault diagnosis units to detect the fault in the induction motor at the earliest otherwise motor failure may lead to closure of plants for some time resulting in heavy financial losses. 15% of the asymmetrical faults are the air gap eccentricity fault. Static, dynamic and mixed are three types of air gap eccentricity faults in the induction motors. Motor Current Signature Analysis (MCSA) is one of the fault detection methods employed for eccentricity fault detection. Many research papers have been published on eccentricity fault detection by MCSA under balanced voltage supply condition [3, 4, 5]. The mixed eccentricity fault in an induction motor is detected by identifying the eccentricity characteristic side band frequency components around the fundamental [5]. The amplitude of these frequency components is used as an indicator to assess the degree of air gap non uniformity in the machine. In this paper, investigations conducted on an induction motor to study

the effect of unbalance in supply voltage on the mixed eccentricity detection by MCSA method are presented.

Unbalance in voltage supply fed to the induction motor can result in the performance degradation of the motor and also shortens its life. Small percentage of voltage unbalance may results in large current unbalance in the motor currents resulting in temperature rise and hence insulation failure in the motor.

National Electrical Manufacturers Association (NEMA) and International Electrotechnical Commission (IEC) standards introduce independent definition for voltage unbalance and one of these is normally used for analysis of electrical machine [6]

(i) NEMA Definition

The voltage unbalance percentage (VUP) at the terminal of a machine, based on the NEMA definition can be expressed as

$$VUP = \frac{\text{maximum deviation from average voltage}}{\text{average voltage}} \times 100\% \quad (1)$$

where only the value of the line voltages have been considered.

(ii) IEC or Symmetrical Components Definition

The voltage unbalance factor at the terminal of a machine based on the IEC definition, is as follows

$$VUF = \frac{V_2}{V_1} \times 100\% \quad (2)$$

where V_1 and V_2 are the magnitude of positive and negative sequence components of unbalanced voltages, respectively [6].

This paper makes use of NEMA definition to study the effect of unbalance supply voltage on the amplitude of mixed eccentricity related frequency components by MCSA. This investigation is carried out in two phases. In phase 1, a dynamic model of an induction motor is developed whose description is given in the Section II. Simulation results are discussed in the Sections III and IV. In phase 2, experiments are conducted on an eccentric induction motor operating under various unbalance supply voltage conditions. In the Section V,

results obtained by the simulating the model under various unbalance conditions are validated by experimental results. It is followed by the Conclusion in the Section VI.

II. MODELING AND SIMULATION

The dynamic model of the induction motor is developed using multiple coupled circuit approach in MATLAB/SIMULINK[®] platform [7,8,9]. The inductances are calculated by using Modified Winding Function Theory [10] and is given by (3)

$$L_{ij} = 2\pi\mu_0 r \ell \left[\langle Pn_i n_j \rangle - \frac{\langle Pn_i \rangle \langle Pn_j \rangle}{\langle P \rangle} \right] \quad (3)$$

where r is the mean radius of the air gap, ℓ is the axial length of the stack, P is the air gap permeance, n_i and n_j are the turn functions of i and j windings respectively.

The stator phase A and rotor loop1 turn functions considered for modeling the machine are given in Appendix. For mixed eccentricity conditions prevailing in the machine, the permeance P is calculated using (4) [11].

$$P(\theta_r, \phi) = P_0 + P_1 \cos(\phi - \rho(\theta_r)) + P_2 \cos(2\phi - 2\rho(\theta_r)) \dots \quad (4)$$

$$P_i = 2 \left[\frac{1}{g_0 \sqrt{1-\delta^2}} \right] \left[\frac{1-\sqrt{1-\delta^2}}{\delta} \right]^i$$

$$\rho(\theta_r) = \tan^{-1} \left(\frac{\delta_d \sin(\theta_r)}{\delta_s + \delta_d \sin(\theta_r)} \right)$$

$$\delta(\theta_r) = \sqrt{\delta_s^2 + \delta_d^2 + 2\delta_s \delta_d \cos(\theta_r)}$$

where g_0 is the length of the air gap under healthy conditions, ϕ is the circumferential angle, θ_r is the rotor position angle, δ_s , δ_d and δ are the static, dynamic and mixed eccentricity indices.

The induction motor model developed in [7, 8] takes stator phase voltages as input. Hence the model is suitable to study the operation of motor under balanced conditions only. To take into account of the unbalance in supply voltages, it is necessary to modify the model which can take line voltages as input. For machines having delta connected stator windings, modifications in the model is not necessary as the line voltages will be same as phase voltages.

But for a star connected machine modifications are necessary in the stator system equations as described below. The voltages equations for the stator loops in vector matrix can be written as given in (5) [7].

$$V_s = \begin{bmatrix} R_a & 0 & 0 \\ 0 & R_b & 0 \\ 0 & 0 & R_c \end{bmatrix} I_s + \begin{bmatrix} \frac{d\lambda_a}{dt} \\ \frac{d\lambda_b}{dt} \\ \frac{d\lambda_c}{dt} \end{bmatrix} \quad (5)$$

where $V_s = [v_a \ v_b \ v_c]^T$, v_a , v_b and v_c are the stator phase

voltages, R_a , R_b and R_c are the stator phase resistances, λ_a , λ_b and λ_c are the stator phase flux linkages and the stator flux is given by

$$\lambda_s = \begin{bmatrix} L_{aa} & L_{ab} & L_{ac} \\ L_{ba} & L_{bb} & L_{bc} \\ L_{ca} & L_{cb} & L_{cc} \end{bmatrix} I_s + \begin{bmatrix} L_{ar} \\ L_{br} \\ L_{cr} \end{bmatrix} I_r \quad (6)$$

where L_{ab} , L_{bc} , L_{ca} are the mutual inductances between three phases and L_{aa} , L_{bb} , L_{cc} are the stator phase self inductances, I_s is a phase current vector $= [i_a \ i_b \ i_c]^T$, I_r is a vector of rotor loop currents $= [i_1 \ i_2 \dots \ i_n \ i_e]$ and L_{sr} is the mutual inductance between stator phases and rotor loops.

By manipulating (5) and (6), V_{sl-1} and λ_{sl-1} are obtained and are given in (7) and (8) respectively [9].

$$V_{sl-1} = \begin{bmatrix} V_a - V_b \\ V_b - V_c \\ V_c - V_a \end{bmatrix} = \begin{bmatrix} R_a & -R_b & 0 \\ 0 & R_b - R_c & \\ -R_a & 0 & R_c \end{bmatrix} I_s + \left[\frac{d\lambda_{sl-1}}{dt} \right] \quad (7)$$

$$\lambda_{sl-1} = \begin{bmatrix} \lambda_a - \lambda_b \\ \lambda_b - \lambda_c \\ \lambda_c - \lambda_a \end{bmatrix} = \begin{bmatrix} L_{aa} - L_{ba} & L_{ab} - L_{bb} & L_{ac} - L_{bc} \\ L_{ba} - L_{ca} & L_{bb} - L_{cb} & L_{bc} - L_{cc} \\ L_{ca} - L_{aa} & L_{cb} - L_{ab} & L_{cc} - L_{ac} \end{bmatrix} I_s + \begin{bmatrix} L_{ar} - L_{br} \\ L_{br} - L_{cr} \\ L_{cr} - L_{ar} \end{bmatrix} I_r \quad (8)$$

For star connected stator, under both balanced and unbalanced conditions, vector sum of three phase currents (line currents) are always zero. Hence sum of its derivative will also be zero. Hence it can be written as

$$I_a + I_b + I_c + \frac{d(I_a + I_b + I_c)}{dt} = 0 \quad (9)$$

where I_a , I_b , I_c are line currents.

Equation (7) cannot be solved. Hence modifications are done as given in [9]. Replacing the third row in (7) by (9), (7) can be written as

$$V_{sl-1} = \begin{bmatrix} V_a - V_b \\ V_b - V_c \\ 0 \end{bmatrix} = \begin{bmatrix} R_a & -R_b & 0 \\ 0 & R_b - R_c & \\ 1 & 1 & 1 \end{bmatrix} I_s + \left[\frac{d\lambda'_{sl-1}}{dt} \right] \quad (10)$$

where λ'_{sl-1} is given by

$$\lambda'_{sl-1} = \begin{bmatrix} \lambda_a - \lambda_b \\ \lambda_b - \lambda_c \\ 0 \end{bmatrix}$$

$$= \begin{bmatrix} L_{aa} - L_{ba} & L_{ab} - L_{bb} & L_{ac} - L_{bc} \\ L_{ba} - L_{ca} & L_{bb} - L_{cb} & L_{bc} - L_{cc} \\ 1 & 1 & 1 \end{bmatrix} I_s + \begin{bmatrix} L_{ar} - L_{br} \\ L_{br} - L_{cr} \\ 0 \end{bmatrix} I_r \quad (11)$$

Since the rotor winding are short circuited, so there is no need for modification of equations on the rotor side. The rotor equations and mechanical equation remain same.

Under unsymmetrical unbalanced condition, magnitude and phase angles of the line voltages will not remain the same. In order to obtain the phase angle of line voltages, the triangle theorem and properties of line voltages are used [12] and are calculated as follows

With V_{ab} as reference, three line voltages are defined as

$$\begin{aligned} \hat{v}_{ab} &= V_{ab} \angle 0 \\ \hat{v}_{bc} &= V_{bc} \angle 180 - \beta \\ \hat{v}_{ca} &= V_{ca} \angle -180 + \alpha \end{aligned} \quad (12)$$

where α and β are defined as

$$\alpha = \frac{V_{ab}^2 + V_{bc}^2 + V_{ca}^2}{2V_{ab}V_{ca}}$$

$$\beta = \frac{V_{ab}^2 + V_{bc}^2 + V_{ca}^2}{2V_{ab}V_{bc}}$$

V_{ab} , V_{bc} and V_{ca} are the line voltages.

Phase angles are computed in m-files with the knowledge of magnitude of three line voltages and brought to SIMULINK model along with the voltage magnitudes as inputs to the model. The developed model is simulated for various unbalance supply voltage conditions and the results obtained are discussed in the following Sections.

III. SIMULATION RESULTS AND PSD ANALYSIS

The selected machine is a Delta connected, 3 hp induction motor having 24 stator slots, 30 rotor bars, 4 poles and the machine parameters are defined in Appendix. The model is simulated using Runge Kutta method using a step size of 0.00005 seconds for different mixed eccentricity conditions for both conditions of balanced and unbalanced supply voltages. 20000 stator data samples of stator phase currents are extracted from the machine running under full load and are filtered using a low pass FIR filter having cut off frequency of 10 kHz. The chosen window is Hann.

Frequency analysis is performed on the stator current data samples to study the effect of supply unbalance on the eccentricity characteristic harmonic frequency components in the current spectra. The spectra obtained by Power Spectral Density (PSD) analysis performed on the data samples of stator phase current of the machine having 30% static eccentricity and 20% dynamic eccentricity under both balance and unbalance conditions are shown in Figure (1). From the figure, it is observed that mixed eccentricity characteristic harmonics ($f_s - f_r$) and ($f_s + f_r$) are present in both the current spectra. But under unbalance conditions third order harmonics are also present in the current spectra.

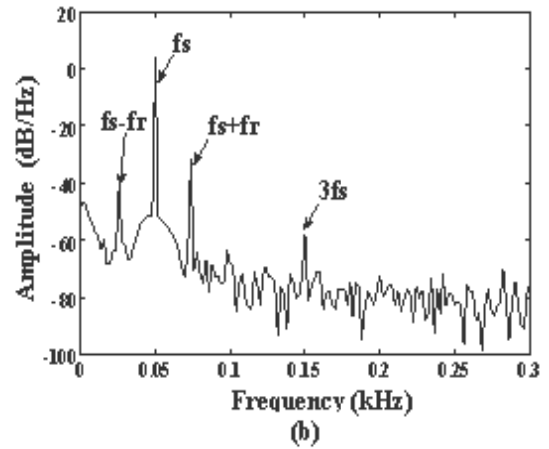
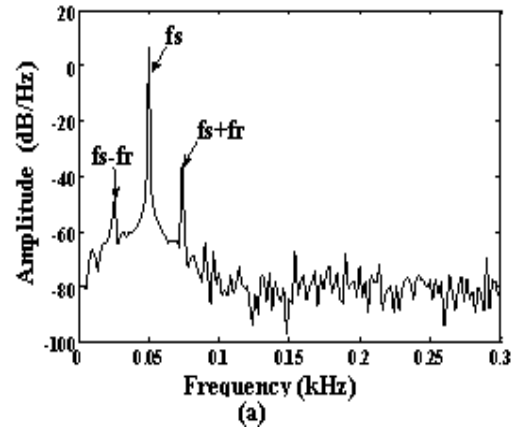

Fig 1. Stator phase A current spectra of the machine under (a) balance supply (b) unbalance supply (2.03%)

The eccentricity related side band frequency components around the fundamental are computed using (13) and are compared with those obtained by PSD analysis in Table (1)

$$f_e = f_s \pm k f_r$$

where $f_r = f_s ((1-s)/p)$ (13)

f_r is the rotor frequency, f_s is the fundamental frequency, s is the slip and p is the pole pairs.

TABLE 1. COMPARISON OF ECCENTRICITY RELATED HARMONICS IN STATOR PHASE A CURRENT

Frequency Components	Full Load	
	$f_s - f_r$ Hz	$f_s + f_r$ Hz
PSD Analysis	26 Hz	74 Hz
Equation	26.16 Hz	73.74 Hz

The results obtained by performing PSD analysis on the stator phase A current data samples of the motor suffering from mixed eccentricity condition and supplied with unbalance voltages are presented in the following Section.

IV. RESULTS AND DISCUSSIONS

Effect of unbalance is investigated for three unbalance supply voltage conditions. They are categorised as

(i) *Over Voltage unbalance Condition:* In this case, line voltage V_{ab} is set at 400V and other two line voltages V_{bc} and V_{ca} are kept more than 400V

(ii) *Under Voltage unbalance Condition:* Both the line voltages V_{bc} and V_{ca} are maintained less than 400V while V_{ab} is kept constant at 400 V.

(iii) *Mixed Voltage unbalance Conditions:* In this case, study is conducted by keeping V_{ab} constant at 400V while one of V_{bc} or V_{ca} is maintained above 400V and the other below 400V.

The model is simulated for the air gap eccentricity conditions of 20% static eccentricity and 20% dynamic eccentricity for the above said three conditions of unbalance voltage and the amplitude of the eccentricity related frequency components are found from the current spectra obtained by performing PSD analysis are tabulated in Table 2-4. The percentage of unbalance is calculated using NEMA definition.

TABLE 2. VARIATION OF MAGNITUDE OF AIR GAP ECCENTRICITY RELATED HARMONICS UNDER OVER VOLTAGE UNBALANCE

	Percentage Voltage Unbalance	f_s-f_r (26Hz) Magnitude	f_s+f_r (74Hz) Magnitude
Over Voltage Unbalance	1% (400,404,408)	-45.11	-35.53
	2% (400,410,415)	-44.43	-35.13
	3% (400,417,420)	-42.9	-35.01

TABLE 3 VARIATION OF MAGNITUDE OF AIR GAP ECCENTRICITY RELATED HARMONICS UNDER UNDER VOLTAGE UNBALANCE.

	Percentage Voltage Unbalance	f_s-f_r (26Hz) Magnitude	f_s+f_r (74Hz) Magnitude
Under Voltage Unbalance	1% (400,396,392)	-46.79	-36.38
	2% (400,392,384)	-47.41	-36.95
	3% (400,385,380)	-48.97	-37.31

TABLE 4 VARIATION OF MAGNITUDE OF AIR GAP ECCENTRICITY RELATED HARMONICS UNDER MIXED VOLTAGE UNBALANCE.

	Percentage Voltage Unbalance	f_s-f_r (26Hz) Magnitude	f_s+f_r (74Hz) Magnitude
Mixed Voltage Unbalance	1% (400,396,404)	-45.83	-35.94
	2% (400,392,408)	-45.93	-35.91
	3% (400,388,412)	-45.83	-35.94

From Table 2-4, following observations are made

- With over voltage unbalance, the magnitude of air-gap related harmonic component increases with increase in percentage unbalance.
- With under voltage unbalance, the magnitude of air-gap related harmonic component decreases with increase in percentage unbalance
- With mixed voltage unbalance, the magnitude of air-gap related harmonic component remain nearly constant with increase in percentage unbalance

The observations made from modeling and simulations are validated by conducting experiments on an air gap eccentric induction motor in the next section

V. EXPERIMENTAL RESULTS

3 hp squirrel cage induction motor is modified to create inclined eccentricity in it. Two end brackets with bores are mounted on either side of shaft and the it can be moved to create inclined eccentricity in the machine. The motor is coupled to a dc generator which is supplying the lamp loads through which the machine is loaded. Inclined static eccentricity of 0.1452 is created at one end is created while the other end (coupling) is healthy. Machine suffers from inherit dynamic eccentricity.

The data acquisition system is built as shown in Figure (2). NI hardware, Hall Effect current transducers is used to build the data acquisition system. Three current Hall Effect transducers are used to sense the three phase currents. They are converted to voltage signals in voltage conversion box and signal conditioned in signal conditioner box. LabVIEW® software is used to acquire and process the current signals. 20000 stator phase current data samples are acquired at 20 kHz through Data Acquisition Card (DAC) and stored as .lvm files for offline analysis. These data samples are further filtered using a digital filter with 1kHz as cutoff frequency.

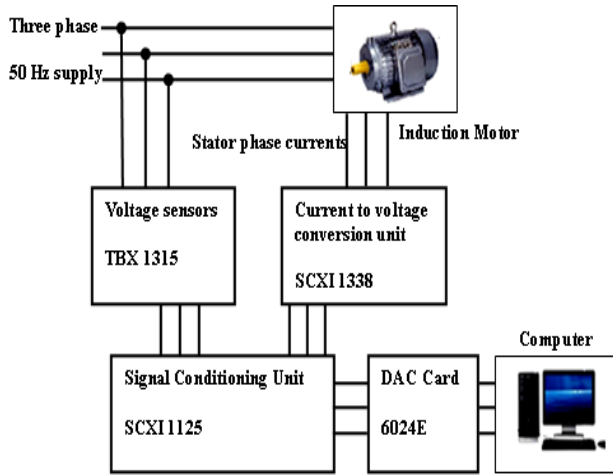

Fig 2 Developed Data Acquisition System

Stator phase A current spectra obtained by PSD analysis performed on the stator phase A current data samples obtained from the machine operating 2% under unbalance condition at full load is shown in Figure (3)

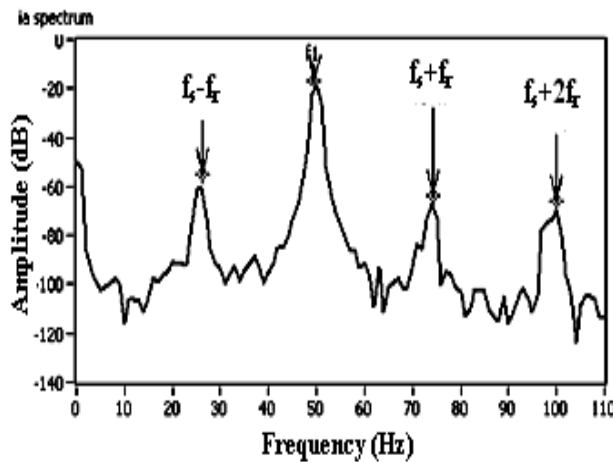

Fig 3 stator phase A Current spectra under unbalance condition (2%)

From the current spectra of stator phase A current, the mixed eccentricity related frequency components ($f_s - f_r$), ($f_s + f_r$) and ($f_s + 2f_r$) are observed at 26.04 Hz, 73.9 Hz and 98.7 Hz respectively. The variation of amplitude of eccentricity characteristic frequency components under over, under and mixed voltage unbalance conditions are given in Table 5.

From the Table 5, following observations are made

With the increase in the percentage unbalance

(i) The magnitude of air-gap related harmonic component increases under over voltage condition.

TABLE 5 VARIATION OF MAGNITUDE OF AIR GAP ECCENTRICITY RELATED HARMONICS UNDER OVER, UNDER, MIXED VOLTAGE UNBALANCE

	Percentage Voltage Unbalance	$f_s - f_r$ Magnitude dB	$f_s + f_r$ Magnitude dB
Over Voltage Unbalance	1.97% (400,408,408)	-62.3	-70.36
	4.86% (400,414,420)	-60.84	-69.63
Under Voltage Unbalance	2.02% (400,392,396)	-59.37	-68.17
	3.04% (400,396,388)	-60.14	-71.09
Mixed Voltage Unbalance	2.99% (400,408,396)	-60.84	-69.63
	4.46% (400,396,414)	-61.57	-73.01

- (ii) The magnitude of air-gap related harmonic component decreases under, under voltage condition.
- (iii) The magnitude of air-gap related harmonic component decreases under, mixed voltage condition.

Results obtained in sections IV and V are summarised in the next section.

VI. CONCLUSION

In this paper, effect of unbalance in supply voltage on the mixed eccentricity detection method by MCSA are studied and analysed for various unbalance voltage conditions by simulating a machine model of a 3 hp induction motor. The result obtained by simulation of the model is validated by conducting experiments on the same machine. It has been found that voltage unbalance does affect the amplitude of the eccentricity characteristic frequency components. It was observed by both experimentally and modeling and simulation that the amplitude of upper and lower eccentricity characteristic side band frequency components around the fundamental

- (i) Increases with increase in percentage over voltage unbalance.
- (ii) Decreases with increase in percentage under voltage unbalance.
- (iii) Remain nearly constant with increase in percentage mixed voltage unbalance under uniform eccentricity throughout the air gap.

Hence it is necessary to account the the effect of unbalance supply voltage while calculating the eccentricity characteristic harmonics amplitude in the eccentricity detection method by MCSA.

APPENDIX

Turn Function of stator phase A

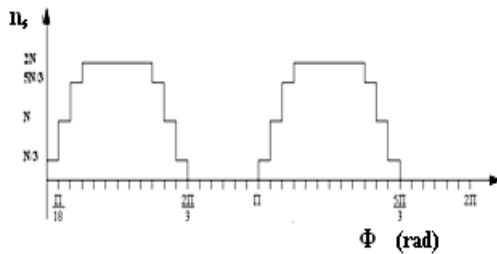

Turn Function of rotor loop1

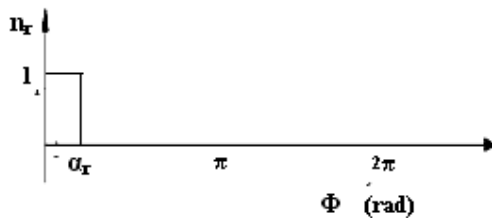

Machine Details:

2.2 kW, 3 ϕ , 400/415 V, 50 Hz, 4 poles, 1440 rpm
 Number of stator Slots = 24
 Number of rotor bars = 30
 Length of stack = 120 mm
 Effective air-gap = 0.35 mm
 Mean radius of air-gap = 89.65 mm
 Stator resistance = 7.6 Ω
 Stator leakage inductance = 38.43 mH
 Number of turn per phase = 400
 Rotor bar resistance = 0.00376 Ω
 Rotor bar leakage inductance = 44.72 μ H
 Rotor end ring segment resistance = 0.0012 mH
 Rotor end ring segment leakage inductance = 1.24 μ H
 Rotor inertia = 0.029 kg-m²

REFERENCES

- [1] Arafat Siddique, G.S.Yadava and Bhim Singh, "A Review of Stator Fault Monitoring Techniques of Induction Motors", *IEEE Transactions on Energy Conversion*, vol.20, no.1, pp. 106-114, March 2005
- [2] S.H.Chetwani, M.K.Shah & Ramamoorthy, "Online Condition Monitoring of Induction Motors through signal processing", *Proceedings of eighth international conference on Electrical machines and systems*, vol 3, 2005, pp. 2175-2179.
- [3] Faiz Jawad; Ebrahim B M; Akin Bilal; Toliyat., "Comprehensive Eccentricity Fault Diagnosis In Induction Motors Using Finite Element Method", *IEEE Transactions on Magnetics*, Vol. 45, no. 3, 2009, pp.1764-1767.
- [4] William T Thomson, "Online motor current signature analysis prevents premature failure of large induction motor drives", *ME maintenance & asset management*, Vol 24, no 3, pp: 30-35, May/June 2009.
- [5] Subhasis Nandi, Hamid A Toliyat, Xiaodong Li, "Condition monitoring and fault diagnosis of electrical motors- a review", *IEEE*

Transaction on energy conversion, vol. 20, no. 4, pp. 719-729, December 2005.

- [6] Jawad Faiz, H. Ebrahimpour, "Precise derating of three phase induction motors with unbalanced voltages", *Industry application conference 40th IEEE/IAS annual meeting Kawloon Hongkong* pp. 485-491, 2-5 October 2005.
- [7] Hamid A Toliyat, Thomas A. Lipo, "Transient Analysis of cage induction machine under stator, rotor bar and end ring faults", *IEEE Transaction on energy conversion*, vol. 10, No. 2, pp. 241-247, June 1995.
- [8] Hamid A Toliyat, S. Arefeen, "A method for dynamic simulation of air-gap eccentricity in induction machine", *IEEE Transaction on energy conversion*, vol. 32, No. 4, pp. 910-918, July/August 1996.
- [9] Xiaogang Luo, Yuefeng Liao, Hamid A. Toliyat, Ahmed El-Antably, Thomas A.Lipo, "Multiple coupled circuit modelling of induction machines" *IEEE Transaction on Industry application*, vol.31, no. 2, pp. 311-318, March/April 1995.
- [10] Jawad Faiz, Iman Tabatabaei, "Extension of Winding Function Theory for Non uniform Air Gap in Electric Machinery", *IEEE transactions on Magnetics*, vol 38, no 6 pp.3654-3657, November 2002,
- [11] Jawad Faiz, Imam Tabatabaei Ardekaneh, Hamid A. Toliyat, "An Evaluation of inductances of a squirrel cage induction motor under mixed eccentric conditions", *IEEE transactions on energy conversion*, vol. 18, no. 2, pp. 252-258, June 2003.
- [12] Jong-Gyeum Kim, Eun-Woong Lee, Dong-Ju Lee, Jong-Han Lee, "Comparison of voltage unbalance factor by line and phase voltage. *IEEE Electrical machine and system conference*, pp 1998-2001, 16 Jan. 2006.